

SPECIFICATIONS

Manhattan

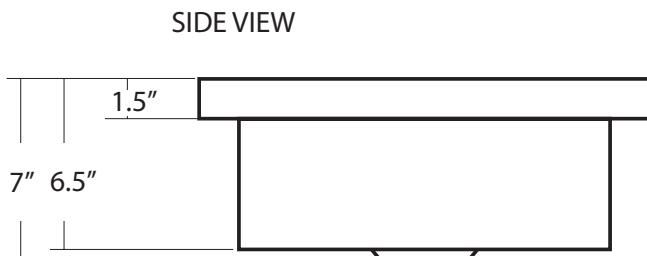

CPS232 - Antique
CPS532 - Brushed Nickel

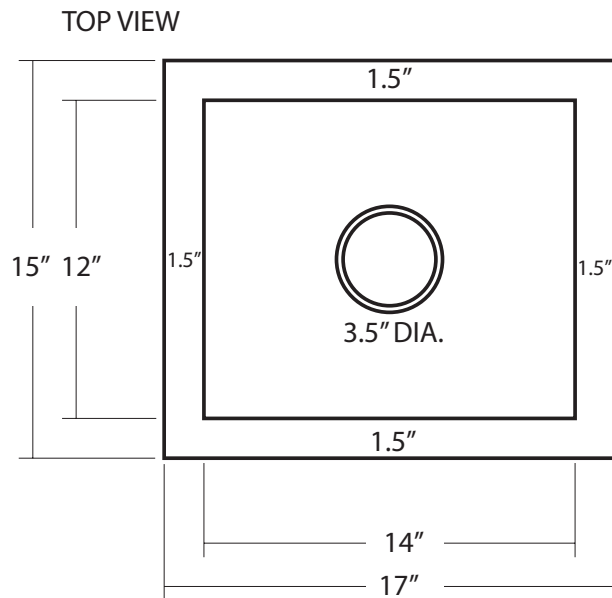

PRODUCT DETAILS

- * 17" x 15" x 7" OD
- * 14" x 12" x 6.5" ID
- * Hand hammered 16 gauge recycled copper
- * 3.5" drain opening

INSTALLATION

- * Bar/Prep
- * Raised Profile

COORDINATING PRODUCTS

- * Drains: DR320 or DR340
- * Bottom Grid: GR913

STANDARDS COMPLIANCE

- * IAPMO Listed / cUPC

IMPORTANT

Due to the handcrafted nature of this product, it may vary in finish, texture, hammering, and other details. Dimensions may vary up to 1/2". We strongly recommend that you wait for the actual product before making any installation cuts.