

SPECIFICATIONS

Americana Large Mirror

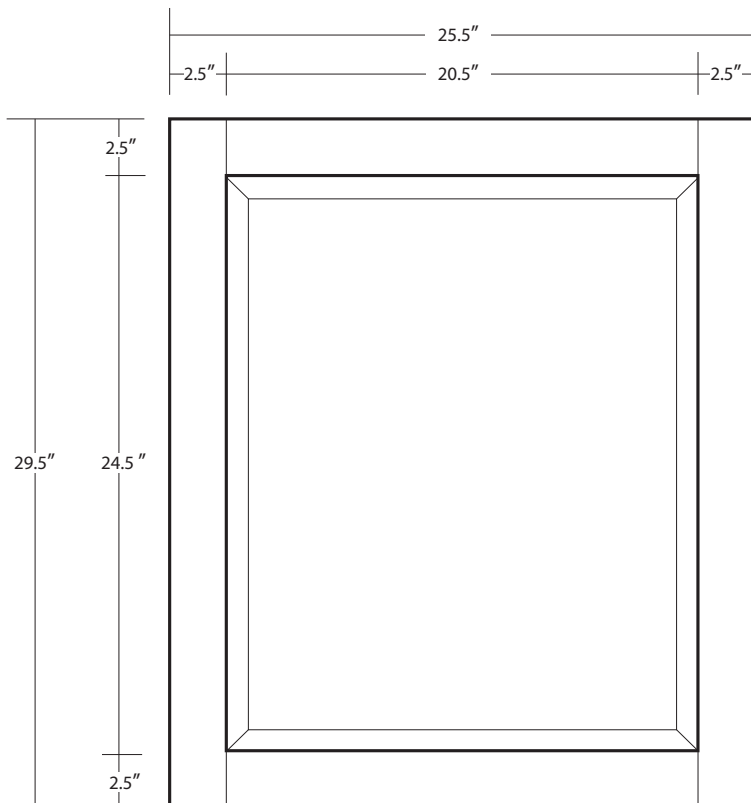

MR291 - Chestnut
MR290 - Whitewash
MR298 - Anvil
MR299 - Driftwood

PRODUCT DETAILS

- * 25.5" w x 29.5" h
- * Reclaimed wood
- * Beveled Glass
- * Hand rubbed finish

INSTALLATION

- * Vertical or Horizontal

COORDINATING PRODUCTS

- * Americana Vanity, Cabinet, Cubby and Hutch

IMPORTANT

Due to the handcrafted nature of this product, it may vary in finish, texture and other details. Dimensions may vary up to 1/2".