

SPECIFICATIONS

30" Cuzco Vanity

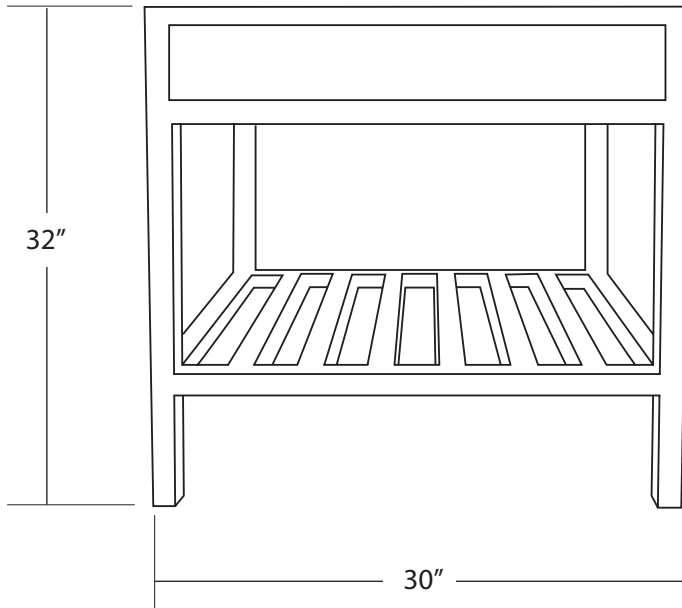

VNR302- Antique
VNR305- Brushed Nickel

PRODUCT DETAILS

- 30"w x 21.5"d x 32"h
- Wrought iron
- Hand hammered 16 gauge recycled copper
- Dimensions are not exact and may vary $\pm\frac{1}{2}$ "

INSTALLATION

- Freestanding vanity base

COORDINATING PRODUCTS

- Native Trails stone and Sedona vanity tops
- Decorative bottle trap

IMPORTANT

Due to the handcrafted nature of this product, it will vary in finish, texture, hammering, and other details. Dimensions may vary up to $\frac{1}{2}$ ".

